

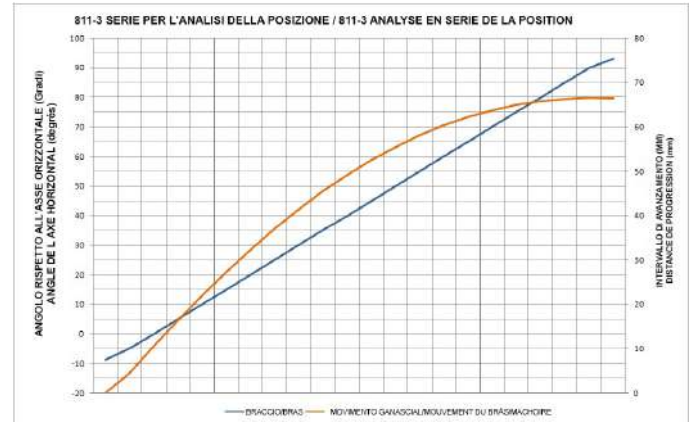

MODELLO NR	F1 (N)	F3 (N)	Fi	PESO (POIDS) (gr ±%)
			CARICO (CHARGE) (F1:Fi)	
811-1	1000	2500	27:1	700
811-2	3500	4500	36:1	1060
811-3	4000	6000	38:1	1600

F1: FORZA DI ESERCIZIO (FORCE EXERCICE), F3: CAPACITÀ DI TENUTA (CAPACITE DE MAINTIEN), Fi: FORZA APPLICATA (FORCE APPLIQUEE)



Base Orizzontale

Base de Montage Horizontale

Caratteristiche del prodotto:

Questi prodotti sono adatti per lavori pesanti.

La ganascia di serraggio è realizzata in acciaio forgiato.

Le altre parti sono realizzate in acciaio zincato resistente alla corrosione.

Caractéristiques du produit :

Les produits sont robustes et adaptés aux applications lourdes.

Le corps est en fonte.

Les pièces du mécanisme sont en acier galvanisé pour une résistance à la corrosion.

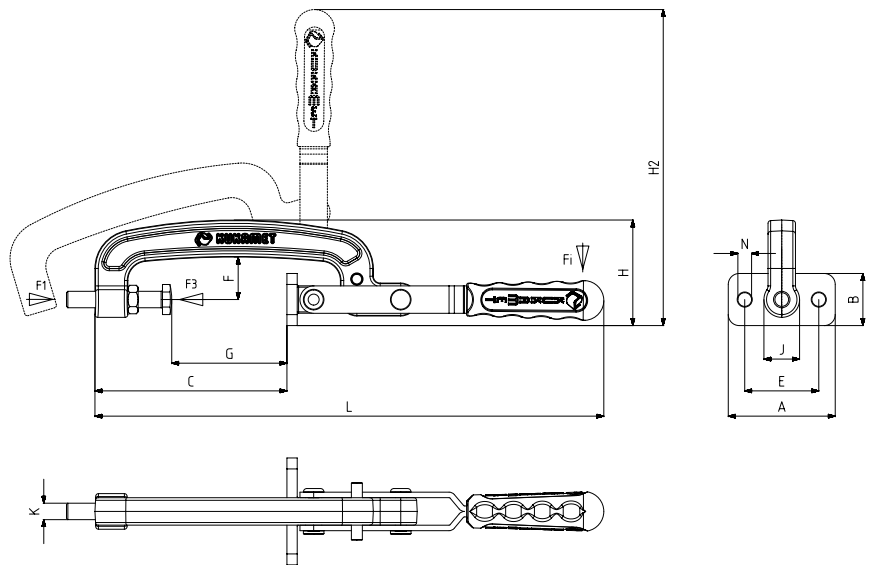

822



841

Pagina/Page: 91

Pagina/Page: 93



MODELLO NR	A	B	C	E	F	G Min.	G Max.	H	H2	J	K	L	N
811-1	58	38	77	40	24	23	50	60	204	16	M8	282	Ø 8
811-2	68	38	110	45	28	46	80	69	217	20	M10	330	Ø 8
811-3	78	38	140	54	31	53	100	77	230	26	M12	372	Ø 10