

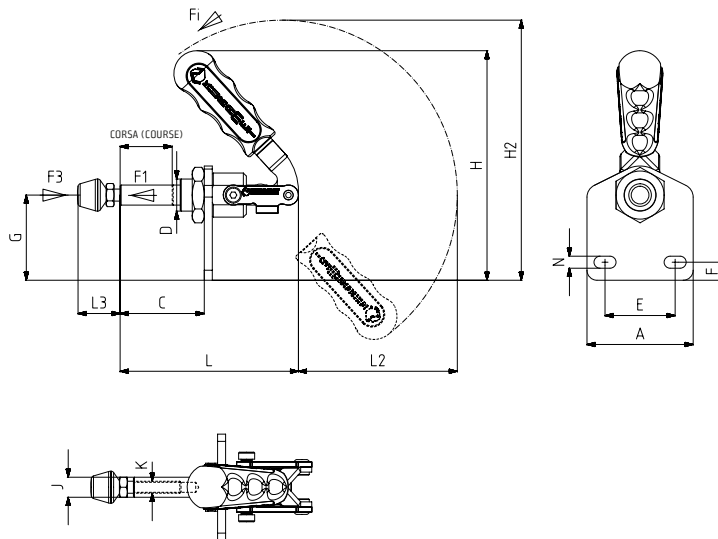

Base Verticale
Base de Montage Verticale

MODELLO NR	INOX	NERO (NOIR)	F1 (N)	F3 (N)	Fi CARICO (CHARGE) (F1:Fi)	FILETTO PUNTALE (FILETAGE PRESSEUR)	CORSA (COURSE)	PESO (POIDS) (gr ±%2)
512 - 2	S 512 -	B 512 -	1500	1700	26:1	M6X40	27	280
512 - 3	-	B 512 -	2500	2640	27:1	M8X50	38	490
512 - 5	-	B 512 -	3500	3700	38:1	M10X70	53	960
512 - 6	-	B 512 -	4500	4650	38:1	M10X70	53	1070

F1: FORZA DI ESERCIZIO (FORCE EXERCEE) , F3 : CAPACITA' DI TENUTA (CAPACITE DE MAINTIEN) , Fi: FORZA APPLICATA (FORCE APPLIQUEE)



511



511-Y



513

Pagina/Page: 54

Pagina/Page: 55

Pagina/Page: 56

MODELLO NR	A	C	D	E	F	G	H	H2	J	K	L	L2	L3 Min	L3 Max	N
512 - 1	44	34	M12 x 1,5	26,5	8,5	35	95	108	8	M5	73	68,5	15	38	5,5 x 10,5
512 - 2	53	42	M16 x 1,5	35	9	42,5	114	129	10	M6	89	80	19	46	6 x 11
512 - 3	60	56	M20 x 1,5	38	12,5	52	158	161	12	M 8	116	80	24	58	6,5 x 11
512 - 5	78	75	M24 x 1,5	49,5	15	64,5	178	206	14	M10	155	135	32	74	8,5 x 16
512 - 6	78	75	M24 x 1,5	49,5	15	64,5	178	206	16	M10	155	135	32	74	8,5 x 16