



MODELLO NR	INOX	NERO (NOIR)	F1 (N)	F3 (N)	FI	FILETTO PUNTALE (FILETAGE PRESSEUR)	CORSA (COURSE)	PESO (POIDS) (gr ±%)
					CARICO (CHARGE) (F1:F3)			
511 - 0 - M	S 511 -	B 511 -	550	700	20:1	M4X25	15	87
511 - 0	S 511 -	B 511 -	550	700	20:1	M4X25	15	92
511 - 1	S 511 -	B 511 -	800	970	24:1	M5X35	22	135
511 - 2	S 511 -	B 511 -	1500	1700	26:1	M6X40	27	280
511 - 3	-	B 511 -	2500	2640	27:1	M8X50	38	490
511 - 5	-	B 511 -	3500	3700	38:1	M10X70	53	960
511 - 6	-	B 511 -	4500	4650	38:1	M10X70	53	1070

F1 : FORZA DI ESERCIZIO (FORCE EXERCEE) , F3 : CAPACITA' DI TENUTA (CAPACITE DE MAINTIEN) , FI : FORZA APPLICATA (FORCE APPLIQUEE)

Base Orizzontale

Base de Montage Horizontale

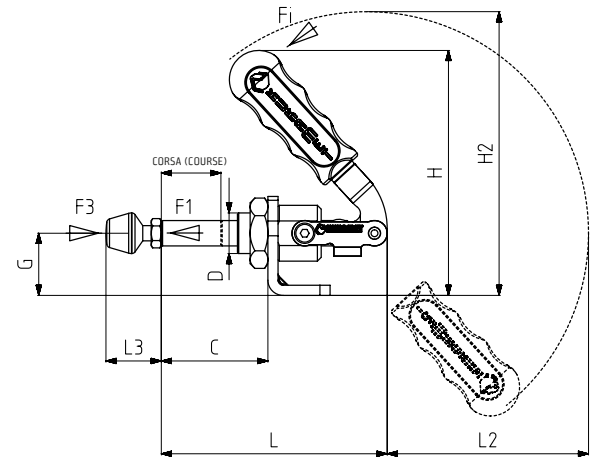

511-Y

Pagina/Page: 55



512

Pagina/Page: 56



513

Pagina/Page: 56



918

Pagina/Page: 122

